

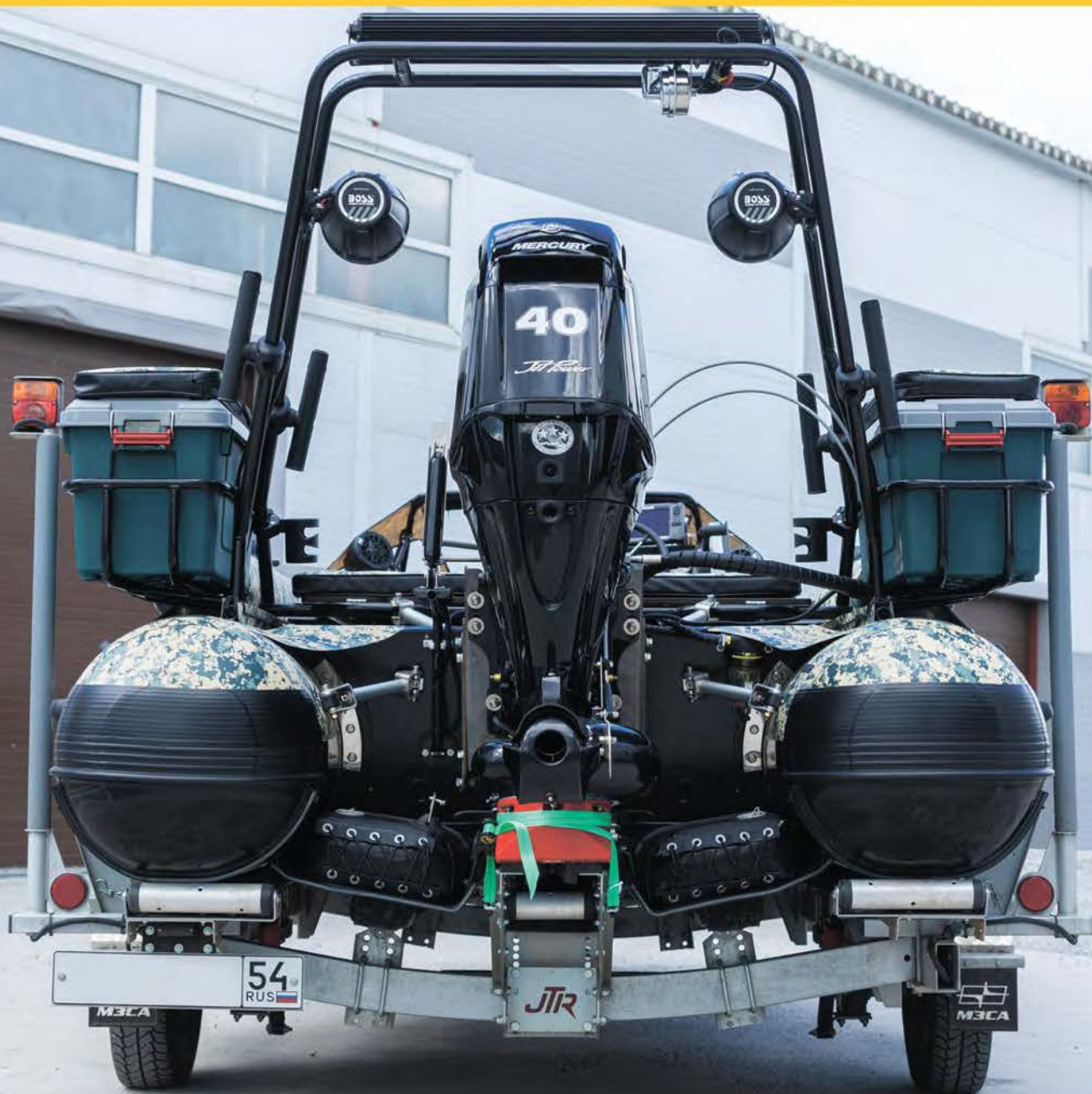

SOLAR

Inflatable motorboats
The LPIB concept founder



**PRODUCT
CATALOGUE**

2023



SOLAR



** The name «SOLAR» is a registered means of individualizing produced goods, which is confirmed by the Trademark Registration Certificate N 486180 from 30.04.2013, and is subject to legal protection in the manner prescribed by the civil law of the Russian Federation. Use of the trademark, not authorized by the owner is not legal and may have legal consequences.*

CATALOGUE CONTENTS

<i>About "SOLAR"</i>	2
<i>Advantages of our boats</i>	3
<i>Models, delivery, warranty</i>	4
<i>Construction, device, bundling</i>	5
<i>Keelboats "SL"</i>	7
<i>Keelboats bundle "Optima"</i>	8
<i>Keelboats bundle "Maxima"</i>	9
<i>SOLAR boats bundle "Expedition"</i>	10
<i>Solar Super Jet (RIB)</i>	12
<i>Solar Strela Jet</i>	13
<i>Solar Super Jet</i>	14
NEW! SOLAR Catamarans	15
<i>Expeditionary set</i>	16
<i>Devices for Solar boats</i>	18



Concept of SOLAR - the new step of evolution of inflatable motor boats!



In 2002 the Russian company Solar received a patent for the invention of a boat with a fully inflatable bottom. Since then, we have been producing a line of inflatable motor boats with a fully inflatable low pressure keel floor.

In the fall of 2013 we started production of our revolutionary tunnel boats. These have become the focus of our production. As time passes, we develop new models designed for use with jet outboard motors. For the 2022 season,

Solar developed an unprecedented line of inflatable motor boats for use in mountain river and extremely skinny water. 15 boats designed for rapids, skinny water, and a wide range of other marine conditions. For the 2023 season we can offer you a boat for all uses and specifically catered to your region and requirements.

Unlike other manufacturers, Solar boats, from the smallest Maxima to the largest Jet Tunnel, have all necessary floor and tube reinforcement. The bottom protection is up to 2.6mm thick and made of layers of reinforced PVC fabric applied during a fully inflated state which allow it to remain unstretched for the life of the boat. Damage to the protective layer during normal use is extremely difficult and allows the boat to be used in shallow rivers with rocky shores, stumps and logs.

Solar boats have been used and tested in the cold waters of the Arctic Ocean and the hot conditions of sunny Spain. Our boats are a familiar sight in the lakes of Karelia, Canada and the great Baikal. They have shown their worth in the mountain rivers of Altai, Khakassia, the Urals, Yakutia, British Columbia and Alaska..

There is so much more to come!...

Join us!



Our company is the pioneer of a new direction in the market of inflatable boats – **PVC boats with LPIB (low pressure inflatable bottom)**. For already more than 18 years we have been actively developing this direction, year by year bringing to market more and more perfect models that meet all the desires of our highly demanding customers.

The SOLAR boats are a fusion of innovation and brand new consumer qualities!

We are working for those who cares about getting only positive vibe from being in touch with nature, trying to make their short days of rest as comfortable and fulfilled as possible!

SOLAR boats advantages

- **Wide model range (30 models)**, consisting of boats designed for different requirements and operating conditions: from mountain rivers to "open water"
- The boats are easy to inflate and get ready to use
- The inflatable bottom is as rigid as that of payole boats and RIB
- Can be used with both screw and waterjet engines
- **The world's best suppliers PVC fabric** used in manufacturing doesn't rot and is oil and gasoline-resistant
- **Hot air welding technology** is actively used in production. All seams have additional protective tapes on both sides
- Back-to-back seams with polyurethane adhesive are additionally glued on both sides with PVC material
- **Possibility to make a lot of additional improvements** to the design, allowing to turn any SOLAR boat into a real "off-road": strengthening of keel, transom, any elements of the boat
- **The boat's light weight.** Due to the absence of plywood of aluminum elements in the bottom structure and their rails
- The bottom also adds to the **softness of movement**. The inflatable bottom perfectly cushions and smoothes out vibrations and shocks of the boat against water during movement, for which your spine and what you sit on will be really grateful!





SOLAR boats models

Keel series (K)		Series (SL)	Catamarans		Tunnel series (Jet tunnel)		
MAXIMA bundle	OPTIMA bundle	ECONOMY bundle	MAXIMA bundle	OPTIMA bundle	Super Jet tunnel (RIB)	Strela Jet tunnel	Super Jet tunnel
		300					
	310						
	330	330					
350	350	350					
380	380	380		380		380	
420			420	420		420	
							430
			460			450	
					470	470	470
480						490	
			520		520	520	520
							555
							595

Accessories

When supplying boats, we take into account the individual needs of each customer!

Upon request, we will install accessories ranging from steering consoles to tents, front rain guards and windscreens. Please see the list of accessories at the back of the catalogue.

Standart delivery package



Boat bag
(1 pc)



Oars
(2 pc)



Seats
(2 pc)



Repair kit
(glue, PVC fabric,
manual)



Foot pump 5 l
(1 pc)



Pressure gauge
(1 pc)

Delivery

The SOLAR inflatable-bottom motor boats are delivered by leading transport companies. You can also buy PVC boats in shops of our official dealers.

SOLAR products warranty

Warranty on all seams, assemblies and parts of boats – 24 months*;

Warranty on PVC material - 5 years.

* SL boats have a 12-months warranty

SOLAR boats design and construction

SOLAR boats are made of several varieties of PVC - fabrics from the world's leading manufacturers (*Heytex, Mehler, MSD, Woonpong and others*), which have different properties for the production of certain boat elements from them..

Optima series

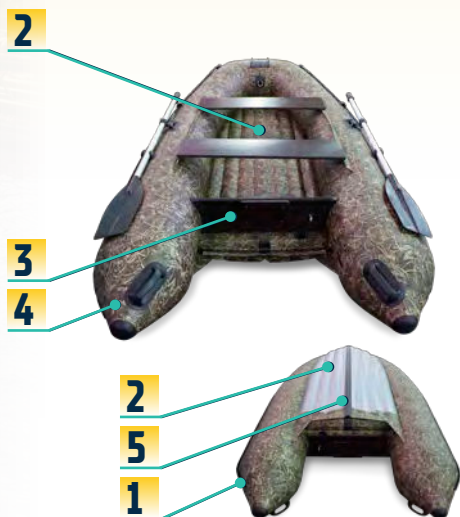

Maxima series



Jet Tunnel series



1 Protector

2 Fully inflatable low pressure keel bottom

3 A transom, securely protected by the bottom

4 Inflatable sections

5 Bottom and tubes additional protection

6 Transom plate for the jet unit

The unique design of our boats is that the deck, considering that it's an inflatable construction, has a **flat, rigid surface**. The possibility of its damaging during operation is minimized. This way, you can stand up and bravely throw spinning or fire a shotgun without the risk of stumbling. For total safety, the deck is covered with a layer of **anti-slip fabric** on top of the deck (in **MAXIMA** and **JET TUNNEL** models).



Round tube

Density of PVC fabric of the round tube, gr/sq.m.

SOLAR boats models	300	310	330*	350*	380	420	430	450	470	480	490	520	555	595
Keel [Optima]		900	900	900	950									
Keel [Maxima]				900	950	1050				1050				
Jet Tunnel [Maxima]					950	1050	1050	1050	1050		1450	1450	1450	1450
SL [Economy]	850		850	850	850									

Number of independent inflatable sections

SOLAR boats models	300	310	330	350	380	420	430	450	470	480	490	520	555	595
Number of independent inflatable sections	3+ bottom	3+ bottom	3+ bottom	3+ bottom	3+ bottom	4+ bottom	4+ bottom	4+ bottom	4+ bottom	4+ bottom	4+ bottom	4+ bottom	4+ bottom	4+ bottom

Strengthening of the lower surface of the tube - 750 g./sq.m

* Except SL series boats



Bottom

Design features of the bottom

A structural feature of **SOLAR** boats is a fully inflatable low pressure bottom (LPIB) keel which provides necessary stiffness and performance. The bottom is glued to the boat's sides and bow in two lines giving the structure a stiffness comparable to a RIB. The rigidity of the bottom is not due to high pressure but rather, vertical bulkheads longitudinally mounted inside the floor structure.

The design of the **SOLAR** boat bottom does not require the use of aluminum or plywood floor structures. It saves weight, set up time and wear and tear on the floor material. The design significantly improves reliability, hydrodynamic and performance characteristics.

More than 15 years of experience in development and production allows us to create boat models that meet a wide variety of operating conditions from open reservoirs to small mountain streams. The **SOLAR** boats meet all modern demands of rescuers, foresters, geologists, meteorologists, oil and gas producers, tourists, hunters and fishermen.

OPTIMA bundle (K)	MAXIMA bundle (K), Jet Tunnel	ECONOMY bundle (SL)
- bottom 1200 gr./sq.m - deck 900 gr./sq.m	- bottom 900+750* gr./sq.m - deck 900+850** gr./sq.m	- bottom 850 gr./sq.m - deck 850 gr./sq.m

*Protection layer

**Anti-slip layer



Transom

To allow the installation of outboard motors the boats are equipped with transoms made of laminated marine plywood. The installation of the transom *above the boat floor* is a unique feature that prevents transom damage due to bottom strikes. Depending on the intended use of the boat, the transom can be ordered for a propellor or jet outboard.



Seats

All boats come equipped with two bench seats made of marine laminated plywood. Fasteners provide reliability during installation and adjustability of the seating locations.



Accessories

Components used in the manufacture of our boats meet all necessary safety, reliability and durability requirements.

Sun Life

SL is a weekend boat made of durable, light weight, single layer PVC fabric.

The boats are designed to be portable for one person and may be used with or without a motor.

The floor of the SL boat is firm and allows for stable standing and walking in the boat despite its size.

The boats are designed for use on lakes and calm bodies of water.

Keel boats
Economy bundle

SOLAR SL



Model color "Oak"

Bottom
850 gr./sq.m

3



Tube
850 gr./sq.m

Additional colors:



"Grey"

1 Protector

2 Keel fully inflatable low-pressure bottom

3 Transom securely protected by the bottom

4 Inflatable sections

Technical specifications:

Model	Dimensions (length, width, diameter of the tube), m	Cockpit size, m	Cargo capacity, kg*	Passengers capacity, persons	Maximum motor power and weight, HP / kg	Weight packed, kg	Package dimensions, m	Boat net weight, kg
SL - 300	3,00 x 1,57 x 0,44	1,90 x 0,67 x 0,30	350	2	9,9 / 26	35	1,10 x 0,48 x 0,37	25,5
SL - 330	3,30 x 1,57 x 0,44	2,19 x 0,67 x 0,30	400	3	9,9 / 26	37	1,15 x 0,55 x 0,44	27,5
SL - 350	3,50 x 1,57 x 0,44	2,43 x 0,67 x 0,30	450	3	9,9 / 26	38,4	1,17 x 0,60 x 0,49	28,8
SL - 380	3,80 x 1,67 x 0,44	2,70 x 0,80 x 0,30	600	4	9,9 / 38,5	42,8	1,26 x 0,63 x 0,50	32,5

Models' dimensions:

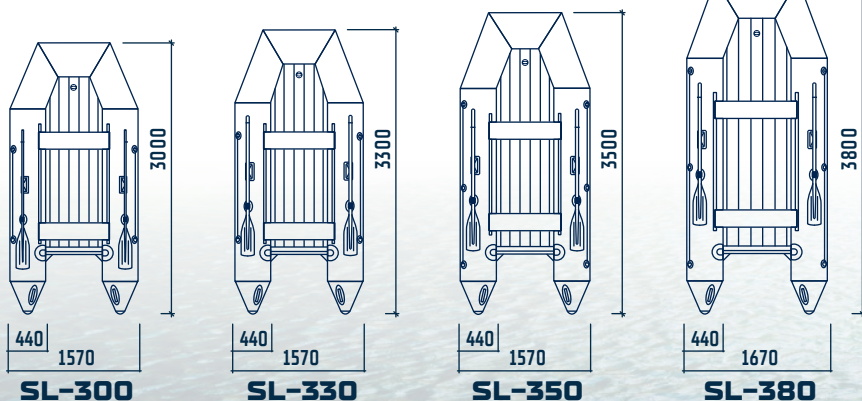

The delivery package includes:



The Optima series of boats is designed with weight and cost in mind. It is a no frills boat that will get you out on the lake exploring with the family, but still comes with the quality expected from an established and known manufacturer

Keel boats
Optima bundle

SOLAR Optima



Model color
"Orange"

Additional colors:



Technical specifications:

Model	Dimensions (length, width, diameter of the tube), m	Cockpit size, m	Cargo capacity, kg*	Passengers capacity, persons	Maximum motor power and weight, HP / kg	Weight packed, kg	Package dimensions, m
Solar - 310 K Optima	3,10 x 1,55 x 0,42	1,95 x 0,73 x 0,30	400	2	15 / 40	45	1,10 x 0,45 x 0,35
Solar - 330 K Optima	3,30 x 1,66 x 0,45	2,10 x 0,74 x 0,30	450	3	15 / 45	47	1,10 x 0,45 x 0,35
Solar - 350 K Optima	3,50 x 1,70 x 0,45	2,40 x 0,80 x 0,30	500	3	15 / 50	49	1,10 x 0,50 x 0,35
Solar - 380 K Optima	3,80 x 1,75 x 0,45	2,65 x 0,81 x 0,37	600	4	20 / 60	58	1,15 x 0,55 x 0,35

Models' dimensions:

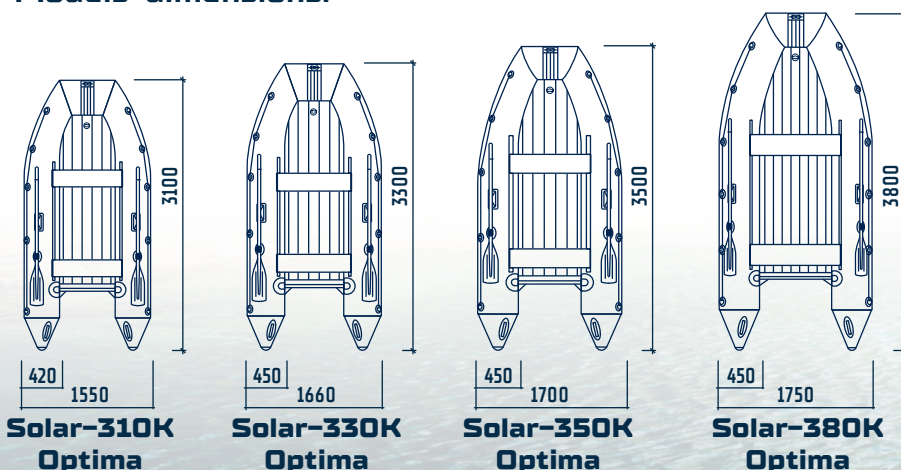

The delivery package includes:



Boat bag (1 pc)



Oars (2 pc)



Seats (2 pc)



Repair kit (glue, PVC fabric, manual)

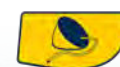

Foot pump 5 l (1 pc)



Pressure gauge (1 pc)

Operation manual (1 pc)
Valve wrench (1 pc)
Buckle (1 pc)

Solar keel boats in the Maxima series are designed for trouble free operation in harsh marine conditions.

Each keel boat has a double safety margin provided by an additional layer of PVC on the bottom.

The boats in the Maxima series have earned their reputation of comfort, durability and payload among fishermen and hunters throughout the world.

**Keel boats
Maxima bundle**

SOLAR Maxima



Tube

950-1050 gr./sq.m

Deck

900+850 gr./sq.m

Bottom

900+750 gr./sq.m

Model color
"Blue"



Lower tube surface

750 gr./sq.m

Additional colors:



"Grey"



"Orange"

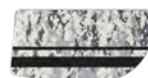

"Pixel"

Technical specifications:

Model	Dimensions (length, width, diameter of the tube), m	Cockpit size, m	Cargo capacity, kg*	Passengers capacity, persons	Maximum motor power and weight, HP / kg	Weight packed, kg	Package dimensions, m
Solar - 350 K Maxima	3,50 x 1,70 x 0,45	2,40 x 0,80 x 0,30	500	3	15 / 50	52	1,10 x 0,50 x 0,45
Solar - 380 K Maxima	3,80 x 1,75 x 0,45	2,65 x 0,81 x 0,37	600	4	20 / 60	62	1,15 x 0,55 x 0,45
Solar - 420 K Maxima	4,20 x 2,00 x 0,50	2,82 x 0,90 x 0,37	800	6	40 / 80	79	1,45 x 0,60 x 0,45
Solar - 480 K Maxima	4,80 x 1,85 x 0,50	3,55 x 0,85 x 0,39	800	6	50 / 90	102	1,30 x 0,55 x 0,55

Models' dimensions:

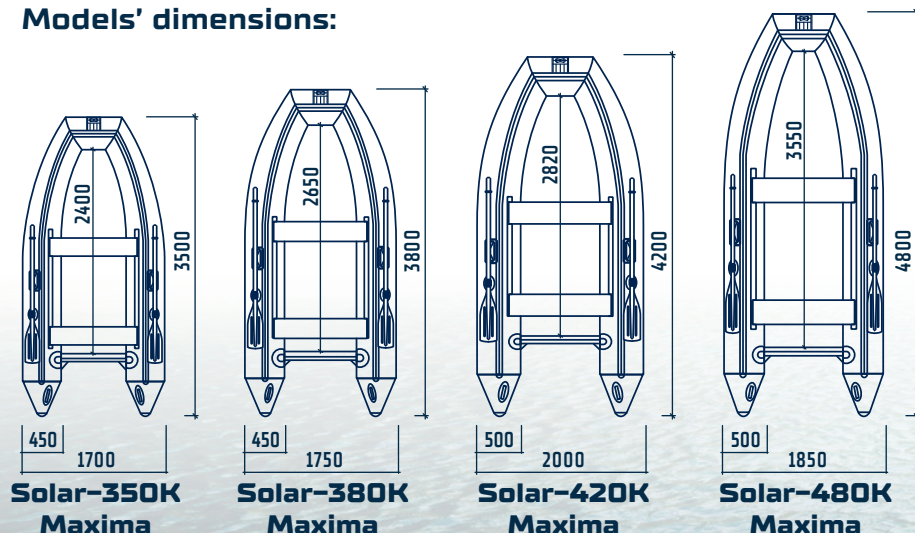

The delivery package includes:



Boat bag (1 pc)



Oars (2 pc)



Seats (2 pc)



Repair kit (glue, PVC fabric, manual)



Foot pump 5 l (1 pc)



Pressure gauge (1 pc)

Operation manual (1 pc)
Valve wrench (1 pc)
Buckle (1 pc)



Bundle Expedition

Solar boats with the Expedition package have the maximum level of reinforcement required for use in all rivers and conditions.

Rocks, log jams, sand bars and rapids are no longer a concern.

These boats have been used and tested in the rivers of Siberia, Alaska, Canada and New Zealand.

Expect unsurpassed reliability and durability from Solar Tunnel Boats with the expedition package!









"Expedition" patch is the distinguishing sign of each boat of "Expedition" bundle



Solar Expedition boats are fully equipped. Installed on the boats are:

- 1 The bottom of the boat has a full layer of polyurethane reinforcement. The protection covers the boat from the rub rails on the sides of the tubes and across the entire bottom *(see page 21)*
- 2 Fixed 20 cm bulwark *(see page 26)*
- 3* Transom reinforcement set for motors up to 60 HP
- 4 Elongated interceptor. Increases max payload and reduces time to get on step
- 5 Front raincover *(see page 26)*
- 6 Cargo compartment

The delivery package includes:

- | | | | |
|--|---|---|---|
|  |  |  |  |
| Boat bag (1 pc) | Oars (2 pc) | Seats (2 pc) | Tab for additional waterjet engine installation (1 pc) |
|  |  |  | |
| Repair kit (glue, PVC fabric, manual) | Foot pump 5 l (1 pc) | Pressure gauge (1 pc) | Operation manual (1 pc)
Valve wrench (1 pc)
Buckle (1 pc) |

* **Micro vibrations are induced as the boat hits an obstacle, this in turn gets transferred to the transom. The transom reinforcement braces absorb the micro vibrations and reduce transom damage**
Two stainless steel plates are also installed on the transom in the expedition package. They are designed to mechanically fasten the transom to the tubes and bottom of the boat



Model color "Orange"



Boat models in "Expedition" bundle:

Solar - 420 Strela Jet Tunnel (orange, pixel)	Solar - 470 Strela Jet Tunnel (orange, pixel)
Solar - 430 Super Jet Tunnel (orange, pixel)	Solar - 470 Super Jet Tunnel (2020) (orange, pixel)
Solar - 520 Super Jet Tunnel (red, pixel)	Solar - 555 Super Jet Tunnel (red, pixel)

Solar boats developed the Tunnel Rigid Inflatable Boat (RIB).

These boats are designed to be used in extremely shallow rivers by utilizing an outboard jet motor or to be used as air boats.

First model of a new product class SOLAR RIB-JET S-470

Super Jet Tunnel (RIB)

SOLAR Super Jet (RIB)



Technical specifications:

Model	Dimensions (length, width, diameter of the tube), m	Cockpit size, m	Cargo capacity, kg*	Passengers capacity, persons	Maximum motor power and weight, HP / kg	Weight packed, kg	Package dimensions, m
Solar - 470 Super Jet (RIB)	4,70 x 2,00 x 0,50	3,67 x 0,90 x 0,43	800	6	60 / 130	188	4,30 x 1,30 x 0,70
Solar - 520 Super Jet (RIB)	5,20 x 2,00 x 0,50	4,17 x 0,90 x 0,43	900	7	60 / 130	218	4,80 x 1,30 x 0,70

Models' dimensions:

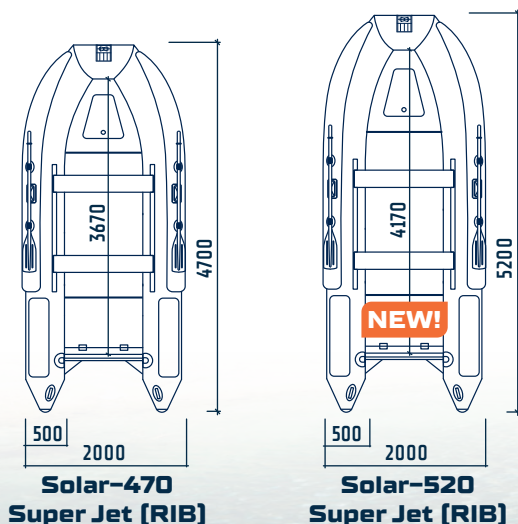

The delivery package includes:

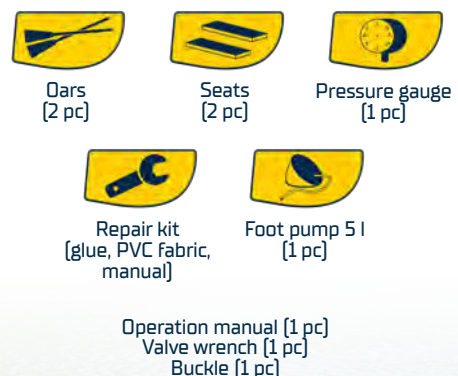

Strela Jet Tunnel- these boats have taken on the most dangerous and narrow rivers of Siberia and Sakhalin and come out on top. Excellent results can be expected in terms of cross country travel, maneuverability, speed and payload capacity

The boats for the real Boy Scout and his friends.

Strela Jet Tunnel

SOLAR Strela

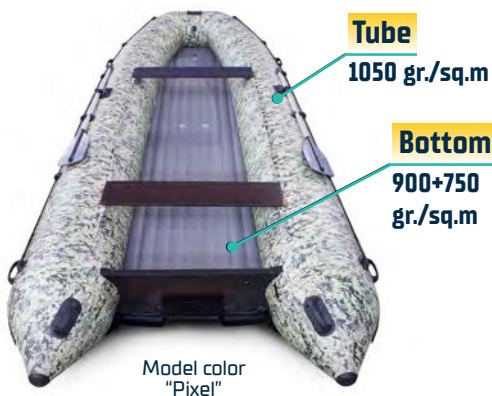

Additional colors:



"Grey"



"Orange"



"Blue"

Technical specifications:

Model	Dimensions (length, width, diameter of the tube), m	Cockpit size, m	Cargo capacity, kg*	Passengers capacity, persons	Maximum motor power and weight, HP / kg	Weight packed, kg	Package dimensions, m
Solar - 380 Jet Tunnel	3,80 x 1,75 x 0,45	2,70 x 0,81 x 0,37	600	4	30 / 80	66	1,40 x 0,55 x 0,40
Solar - 420 Strela Jet Tunnel	4,20 x 1,75 x 0,45	3,15 x 0,81 x 0,37	700	5	30 / 80	75	1,40 x 0,70 x 0,40
Solar - 450 Strela Jet Tunnel	4,50 x 1,75 x 0,45	3,40 x 0,81 x 0,35	800	6	40 / 80	85	1,30 x 0,50 x 0,50
Solar - 470 Strela Jet Tunnel	4,70 x 1,90 x 0,50	3,70 x 0,85 x 0,38	800	6	50 / 90	86	1,40 x 0,60 x 0,55
Solar - 490 Strela Jet Tunnel	4,90 x 2,00 x 0,60	3,90 x 0,80 x 0,45	800	7	60/130	95	1,60 x 0,60 x 0,50
Solar - 520 Strela Jet Tunnel	5,20 x 2,05 x 0,55	4,30 x 0,95 x 0,43	900	8	115/190	125	1,60 x 0,65 x 0,55

The delivery package includes:

see page 11 - additional equipment of Expedition

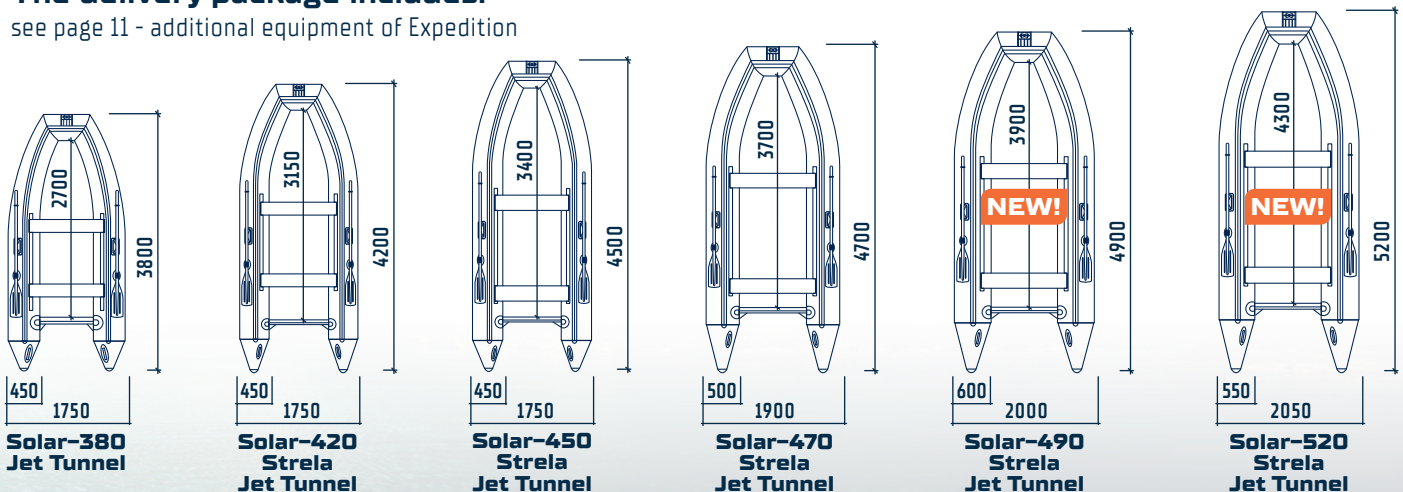

The Super Jet Tunnel boats excel in extremely skinny water and can be used to cross virtually ankle deep bodies of water while loaded. Thanks to the wide beam, these boats have excellent buoyancy and interior space for payload and passengers.

Absolutely universal expeditionary models.

Super Jet Tunnel

SOLAR Super Jet



Tube
1050-1450 gr./sq.m

Tube armour
750 gr./sq.m



Model color "Orange"

Additional colors:



"Pixel"



"Red"

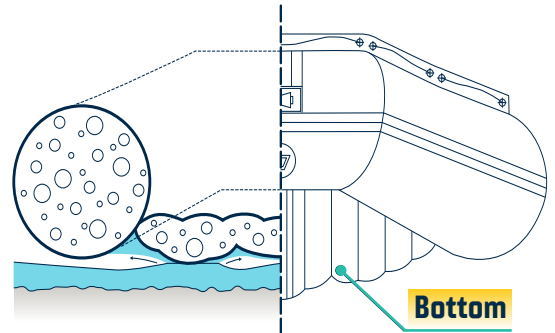

Bottom
900+750 gr./sq.m

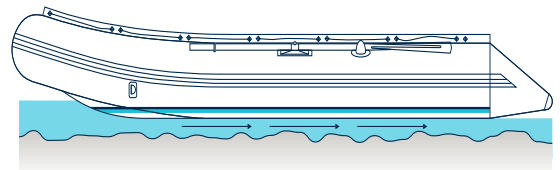

Technical specifications:

Model	Dimensions (length, width, diameter of the tube), m	Cockpit size, m	Cargo capacity, kg*	Passengers capacity, persons	Maximum motor power and weight, HP / kg	Weight packed, kg	Package dimensions, m
Solar - 430 Super Jet Tunnel	4,30 x 1,90 x 0,50	3,38 x 0,80 x 0,32	700	5	40 / 80	83	1,20 x 0,45 x 0,45
Solar - 470 Super Jet Tunnel	4,70 x 1,95 x 0,50	3,65 x 0,93 x 0,32	800	6	50 / 90	95	1,40 x 0,60 x 0,55
Solar - 520 Super Jet Tunnel	5,20 x 2,23 x 0,58	4,30 x 1,05 x 0,38	1100	9	115 / 190	130	1,55 x 0,65 x 0,55
Solar - 555 Super Jet Tunnel	5,55 x 2,23 x 0,58	4,65 x 1,05 x 0,38	1200	10	115 / 190	140	1,55 x 0,65 x 0,65
Solar - 595 Super Jet Tunnel	5,95 x 2,23 x 0,58	5,10 x 1,05 x 0,38	1200	10	115 / 190	140	1,80 x 1,30 x 0,70

The delivery package includes: see page 8 - Optima bundle

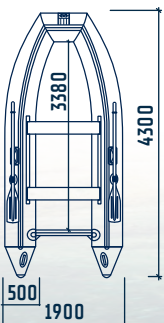

Solar-430 Super Jet Tunnel

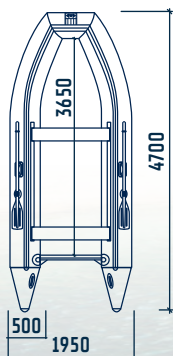

Solar-470 Super Jet Tunnel

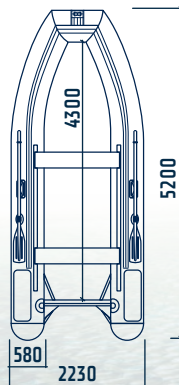

Solar-520 Super Jet Tunnel

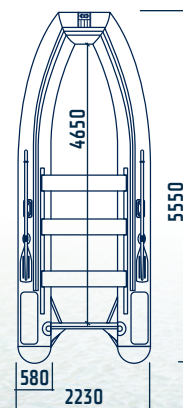

Solar-555 Super Jet Tunnel

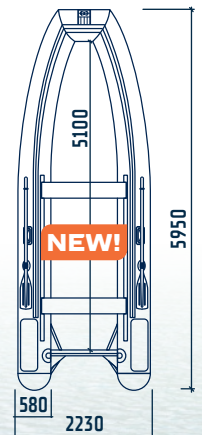

Solar-595 Super Jet Tunnel

Solar STRANNIK Catamarans are designed for cross country expeditions. The boats have a light weight, sea worthy hull and a high volume cockpit allowing for high payload voyages in comfort.

The hull design is extremely stable due to the catamaran design

The wave at speed without obstacles.

The boat is extremely maneuverable and direction changes up to 90- degrees are possible at high speeds. You will be amazed by the speed and handling characterises of this design

NEW!

Catamarans

SOLAR Strannik



Skegs

Limber holes

Limber holes have been installed on the sides of the transom, allowing large volumes of water to be drained quickly and efficiently

Additional colors:



"Oak"

Tube
1050 gr./sq.m

Model color "Grey"

Deck
900+850 gr./sq.m



Bottom
900+750 gr./sq.m

Technical specifications:

Model	Dimensions (length, width, diameter of the tube), m	Cockpit size, m	Cargo capacity, kg*	Passengers capacity, persons	Maximum motor power and weight, HP / kg	Weight packed, kg	Package dimensions, m
Solar - 380 Strannik (Optima)	3,80 x 1,85 x 0,45	2,75 x 0,95 x 0,30	600	4	20 / 55	71	1,45 x 0,50 x 0,45
Solar - 420 Strannik (Optima)	4,20 x 1,85 x 0,45	3,15 x 0,95 x 0,30	700	4	30 / 80	89	1,45 x 0,60 x 0,47
Solar - 420 Strannik (Maxima)	4,20 x 1,85 x 0,45	3,15 x 0,95 x 0,30	700	5	40 / 80	91	1,45 x 0,60 x 0,47
Solar - 460 Strannik (Maxima)	4,60 x 1,85 x 0,45	3,55 x 0,95 x 0,30	800	6	50 / 80	109	1,45 x 0,65 x 0,50
Solar - 520 Strannik (Maxima)	5,20 x 1,85 x 0,45	4,15 x 0,95 x 0,30	900	8	50 / 90	136	1,45 x 0,65 x 0,57

The delivery package includes: see page 8 - Optima bundle

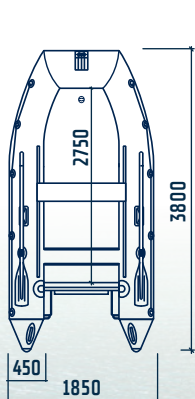

Solar-380 Strannik (Optima)

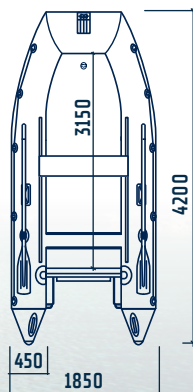

Solar-420 Strannik (Optima)

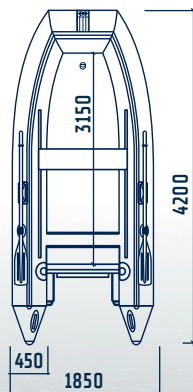

Solar-420 Strannik (Maxima)

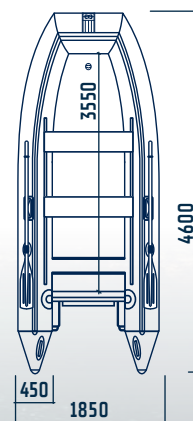

Solar-460 Strannik (Maxima)

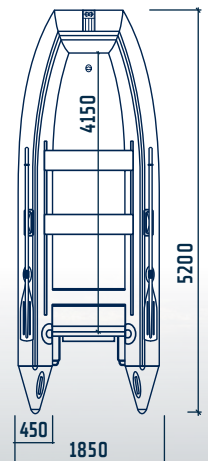

Solar-520 Strannik (Maxima)



Expeditionary set

Solar Boats presents the Solar 520 Strela Jet Tunnel 2023 NEW Inflatable Boat with Mercury Jet 40 ELPT EFI + M3CA trailer

The boat is designed and equipped for long expeditions on mountain rivers.

Remote control consoles and convenient accessories can be pre installed at the factory

Each boat is custom designed and built to your exact specifications.

SOLAR



Boat model:
Solar-520 Strela Jet Tunnel

In the photos, you can see the details and improvement made to this model

We can offer turn-key tuning on any boat, keel or tunnel, starting **from 300** model.

By entrusting us with assembly of the set, you will feel the level of ideas achieved in reality!



1 Custom boat and motor cover



2 Turn Key M3CA Trailer

Inside equipment:

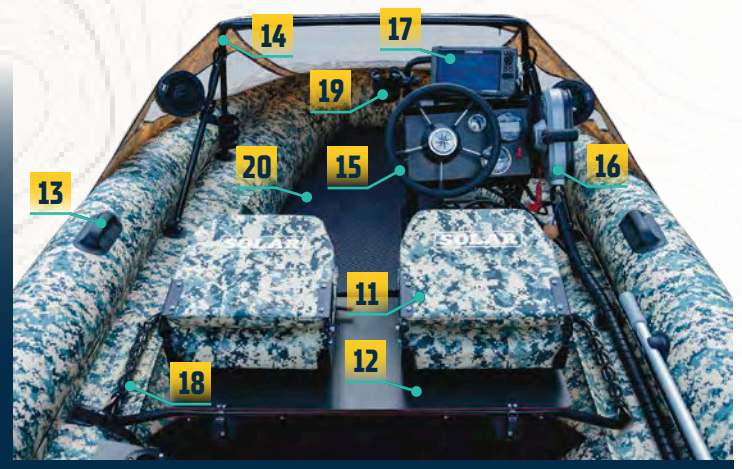
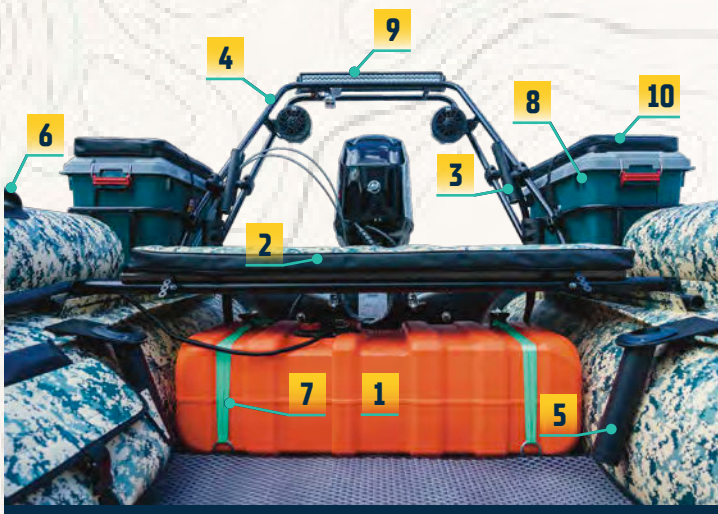

- 1** 84 Litre Fuel tank
- 2** Soft seat cushion on FISH PLATFORM
- 3** Rod holder (arch mount)
- 4** Double steel arch with baskets and fish deck
- 5** Rod Holder (side rail mount)
- 6** PVC handle
- 7** Fuel tank fastening kit
- 8** IRIS box 700
- 9** Aurora LED lightbar
- 10** Seat cushion for box lid

- 11** Padded Pixel seats with the Solar logo
- 12** Storage locker with hinged lid
- 13** PVC handles for driver and passenger
- 14** Reinforced front rain cover in Pixel
- 15** Remote motor controls
- 16** Remote motor controls
- 17** Lowrance Sonar
- 18** Storage locker frame
- 19** Cup holder
- 20** EVA Floor mat



Accessories for **SOLAR** boats







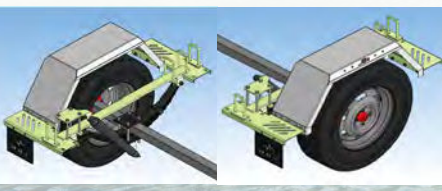

M3CA trailer with additional equipment

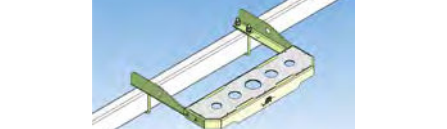

Trailer for the expedition boat.

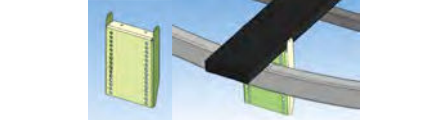
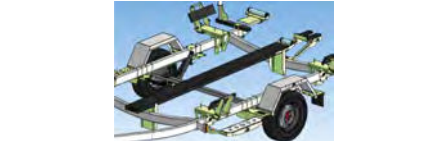
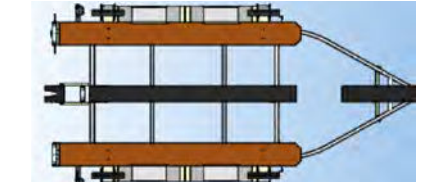
The illustration on the left is of the fully equipped trailer. All accessories perfectly fit the standard boat trailer and add function.

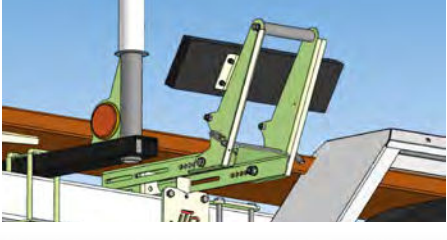
	Name		Description
1	Pre wired Boat guide poles. Relocate kit for the tail lights. Includes brackets		With the removal of position lamps, stop lamps and direction indicators up. Includes two lantern mounting brackets, 4m transfer cable, two 4pin waterproof connectors, 4pcs nylon screeds, PVC armour for 2m cable, connection diagram.
2	Motor support bracket for prop or Jet		Mounted on the crossbar of the trailer frame, on pipe profile 80x40 mm 100x50 mm
3	Side mount rollers		Fitted under a board width of 100-300 mm, Allows you to install the wheel-in roller with offset in any direction. The set includes all necessary installation fasteners + drill.
4	Center roller		They are mounted on a board 200 mm wide. The set includes all necessary installation fasteners + drill.
5	Wheel Fender Steps ALS2, the fenders serve as a step to get in and out of the boat while on the trailer.		Are a power element, serve as a «threshold» for getting into the cockpit of the boat. Maximum permissible load 150-180 kg. Fitted on all trailers as on «stock» fastenings, as well as on reinforced fastenings from JTR.
6	Reinforced fender fastening system		They are installed both on the «stock» version of the trailer and on the «extended». For all kinds of frame trailers M3CA. Very rigidly fix the wing on the trailer frame, completely exclude the effect of «twisting» wing. Serve as additional thresholds. Complete with necessary fastener, additional four ladders, installation instructions.

	Name		Description
7	Double axle reinforced fender mounting system		They are installed both on the «drain» version of the trailer and on the «extended». For all kinds of frame trailers M3CA. Includes all necessary support, additional ladder, installation instructions.
8	INTERNAL mud flaps for fenders		Set on the inner wing plane, to protect the boat from dirt, sand, stones, etc. during transportation.
9	Force steps		2pcs set, with attachments to the trailer frame. Fitted at the bottom and top of the trailer frame. For profile 50x100 «G» And for the profile 40x80 «E»
10	Fastening of the registration plate and registration plate backlight		Set down. In case of transfer of back lamps to side gate - under the left side board.
11	Side lamp protection		Designed to protect position lamps from flying stones from under the wheels of a car.
12	CKB support (central keel board)		Fitted to pipe profile 50x100 40x80
13	CKB (central keel board)		Draughted by commercial carpet, for external use, resistant to UV. Dimensions 2800x200x50 mm Installed on trailers of the brand «G» and «E».
14	Side bunks		Made of one-piece lamellar furniture shield, soaked with antiseptic stain against fungus, the surface is covered with yacht varnish. Additionally tightened to the full width with self-tapping screws [length 200mm] from drying out. Dimensions 3000x300x40mm. They have greater bending strength than conventional boards.
15	Bunk support bracket		Universal power fastening, mounted on any trailer frame (E, G), adjustable for mounting height and for any boat width. Designed for side boards from 200 to 300 mm width.
16	Side bunk support bracket. The kit comes with all necessary parts to mount a side support bunk, which also works as a step when folded down		It is a novelty of our production, is a single unit of parts, which includes: - Supports for side boards with height adjustment of a board. - Side support is foldable, which makes it easy to put the transport tent on the boat. - The function of the threshold, when thrown aside. You can step on it, it is convenient to load-unload the boat.
17	Spare wheel mount		It is mounted on the trailer's drawbar or frame. It has adjustment of the frame radius. Drilling of the mounting holes. 98x4 mm and 139,7x5 (VAZ, NIVA).



Tents

Driving transformer tent

The tent, commonly known as a boat canopy is popular among boat owners. The tent allows for comfortable usage of your boat in inclement weather conditions.

The panels of the tent allow for quick and easy adjustment to the tent configurations. The stern, bow and side panels can all be opened individually while the rest of the structure remains in place to provide protection from the elements.



Available colors:



"Blue-grey
camo"



"Bulrush"

Bow tent

The PVC bow tent is designed to protect occupants and cargo from overlapping waves. The tent has an aerodynamic design directing the wind over the occupants in the cockpit.



Available colors:



"Black"



"Camouflage"





Additional boat protection

Protection of tubes and bottoms with polyurethane

Additional protection to the bottom of the floor and tubes is the most effective way to protect the boat from punctures due to hazards.

Thanks to its properties, polyurethane offers excellent puncture and abrasion resistance.

The polyurethane film is applied to a fully inflated and pre glued boat. The boat remains inflated for 48 hours allowing for the polyurethane to stay in its natural state and not become stretched during installation. After the gluing process the boat is polymerized to cure the glue.

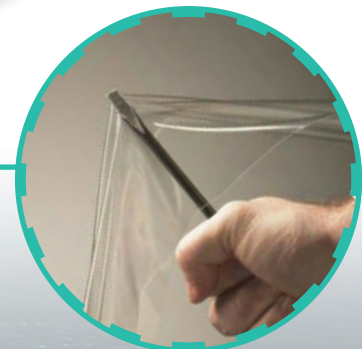
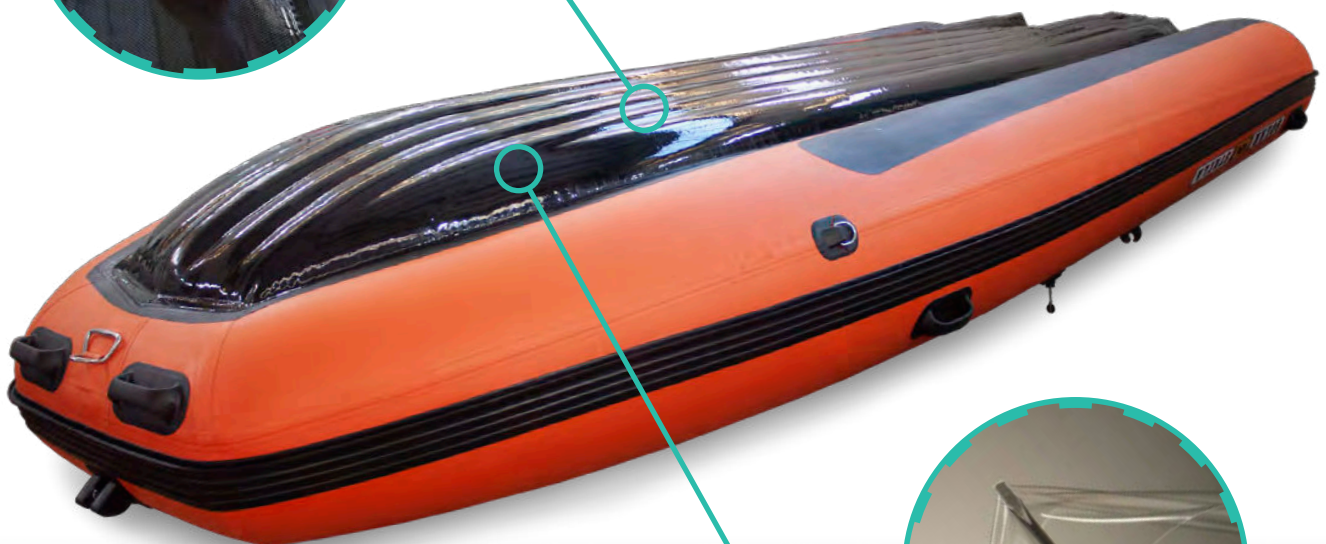



Seat covers

Seat covers are offered with and without a zip in dry bag.

The sealed seams and zippers of the dry bag allow for water resistant cargo securement and organization. Having the bags, allows for convenient storage of loose items that would otherwise clutter the cabin. The bags can be unzipped and removed for convenient transport with the supplied carrying strap.

The covers and bags are made of boat PVC fabric. They are waterproof and not prone to fungus and rotting.



SOLAR boats models	Length, mm	Width, mm
SL - 300, 330, 350, 380; Optima - 310, 330, 350	960	230
Optima - 350, 380; Maxima - 350, 380, 480 Jet Tunnel - 380; Strela - 420, 450, 470; SJT - 430	1100	230
Maxima - 420; Jet Tunnel - 420, 500; SJT - 470	1230	230

Box pad

The seat pad is perfectly fitted to the IRIS 700 Cargo box.

The pad creates a convenient comfortable seat out of the cargo bin allowing for use while camping or in the boat.

The pad is made of embedded foam and covered in PVC





Expedition repair kit



Repair kit composition			
Nº	Name	Quantity (volume, size)	Usage
1.	Polyurethane glue	150 ml (2 pc)	Gluing of leather, rubber, polyurethane, PVC, chipboard, etc.
2.	Degreasing liquid	100 ml	Cleaning and degreasing of glued surfaces
3.	PV fabric 1000 gr.m.	15x90 cm	Repair of tube damage (cut)
4.	PVC fabric 640 gr.m.	15x90 cm	Repair of the bottom duplication layer damage (cut)
5.	PVC fabric 1000 gr.m.	18x20 cm (2 pc)	Repair of tube damage (puncture)
6.	PVC fabric 640 gr.m.	18x20 cm (2 pc)	Repair of the bottom duplication layer damage (puncture)
7.	Non-fabric material	18x20 cm (2 pc)	Cleaning and degreasing of glued surfaces
8.	Folding oar pinch (supinator)	2 pc	Replacement if broken
9.	Gasket for intake valve	2 pc	Intake valve tampering elimination
10.	Intake valve adapter	1 pc	Replacement if broken
11.	Spare tube	2 pc	Temporary replacement of a damaged tube



Boat maintenance, diagnostics

SOLAR valve adapter

Ideal for all SOLAR inlet valves.



BRAVO checking pressure gauge

Equipped with bayonet connectors for quick check of pressure in inflatable body and keel elements. Connected directly to the valve. Scale markings up to 1000 mbar.



PVC repair kit

Glue, PVC fabric, repair manual





Stainless arch

Stainless arch with baggage baskets



The arch is removable and can be installed by using grommet tape which allows for a firm and secure mounting method. The baskets are above the main tubes and do not exceed the overall beam of the boat.



Stainless steel arch combined with console and battery holder



This arch is made of 32mm thick walled pipe and is comfortable and practical. It allows for the installation of remote motor controls and a forward location for the motor battery. The frame fits all of our boats.



Boat cover

The boat cover is designed to be used for storage and while trailering. The cover is a straight forward way to protect the boat from road grime and storage dust and UV damage. It's made of canvas and covers the boat from the front to the end of the tubes. If desired, the motor profile may be cut into the cover or an additional motor cover can be used. The cover is designed to perfectly follow the contours of the boat and attaches to the rub rail with provided hooks allowing the boat to be trailered up to 80 km/hr. The cover comes in a carry bag.

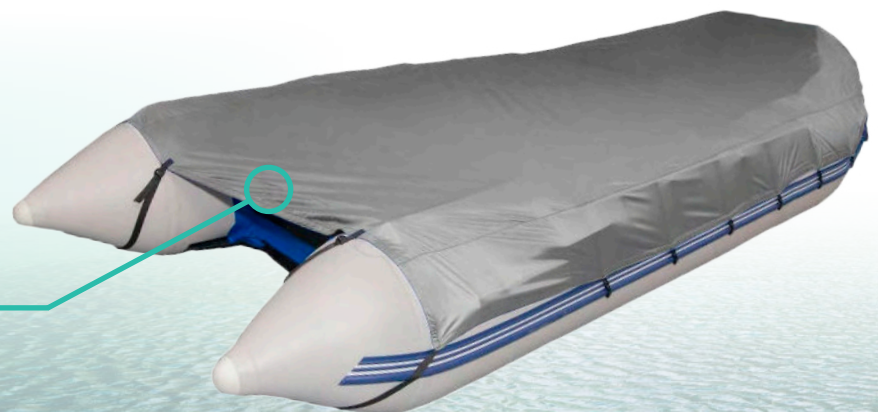



Cockpit mat

Cockpit mat (EVA)

The EVA mat offers excellent floor protection against sand, dirt and mechanical damage.

EVA has excellent thermal insulation, elasticity and plasticity. It won't deform in temperatures from -65C to +85C assuring the protection of the covered surfaces. Ethylene Vinyl Acetate will not absorb moisture and is easily washable with water.

The surface is textured for a slip resistant finish and made up of rhomboid cells. The cells collect the bulk of sand and rocks that get brought into to the boat on shoes, protecting the boat floor surface in the process.

The mat is easily removed, extremely light weight and may be folded and secured with the provided Velcro strap.



Bags, cases

SOLAR bags for tubes

Heavy duty PVC bags to be placed on top of the tubes. Securely mountable with 4 reinforced mounting pads. Easy to detach and attach.



Size: 650x200x180
Colors in stock

Drybag

Convenient dry bags for items that must stay dry.





Front raincover

The front rain cover is a must have while running rapids and technical rivers. The cover will protect boat contents from rain and splashing and unlike taller spray protection will not restrict visibility.

Compact, and convenient, the cover is made of water repellent material and is a great addition to any inflatable boat.

The rain cover is also available factory preinstalled when ordering a boat with attached top bulwarks.



Bulwarks

Bulwarks are two independent inflatable tubes installed on top of the main tubes.

Purpose:

- To increase freeboard
- Increase sea worthiness
- Improve passenger safety and comfort
- Increase in cargo and payload capacity



Remote control

Reinforced steering console F.A.

Side steering console for inflatable boats. Made of aluminum 22mm tube with a thickness of 3mm and AMG5-3mm sheet and finished with powder coating. The console comes with a convenient shelf and a polycarbonate wind screen. The mounting hole for the reduction gear is precut and there is a mounting tab for the throttle controls. The weight of the console is 4KG.

The console has 4 support points which allow for secure mounting. The console design allows for installation of switches, tachometer and additional electronic equipment. The engine throttle controls can be mounted securely allowing for rough water operation while standing.

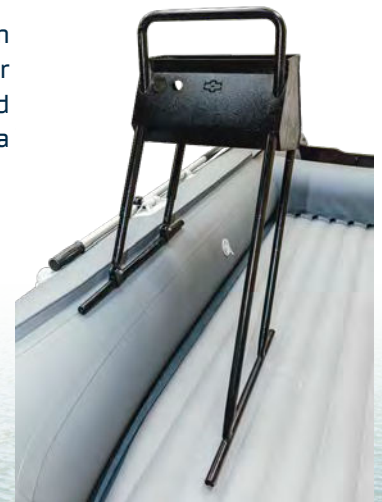



Pumps

BTP-12M electric pump

The Bravo BTP 12 M electric pump is designed for inflatable boats up to 6 m long and has a 12V power supply. This electric pump is equipped with a pressure regulator up to 1000 mbar and an integrated pressure gauge, has two stages with a production capacity of 160 and 450 l/min and connectors to the battery terminals.

The Bravo BTP 12 M pump comes with a set of adapters and a carrying bag.

Size:
30 x 20 x 16 cm



BRAVO BST 800 electric pump

Electric boat pump with 12 V supply (maximum operating current 13 A) and capacity 160/450 l/min, providing a maximum pressure of 800 mbar. The pressure can be set with a regulator located on the pump housing.

The Bravo BST 800 Boat Pump Set includes a cable with alligator battery connectors, carrying bag, air hose and adapter set.

Package size:
21 x 24 x 21 cm



Golfstream GP 80 electric pump

Bravo BST12 analogue.
Voltage: DC12V
Current strength: 20A
Capacity, l/min: 500
Uninterrupted functioning time: 15 min
Air pressure: 10 kPa - 80 kPa (0.1 - 0.8 bar)
Pressure regulator setting step value: 5 kPa
Air hose diameter: 20.5 mm
Air hose length: 1.8m
Cable length: 3 m
Power connection: clamp for the battery
Noise level: 67 Db/7m
Warranty: 6 months.



BRAVO 6 manual pump

Manual two-way pump, volume 6 litres.



Jilong (Relax 12w) electric pump

Electric pump for inflating / deflating products powered by the vehicle cigarette lighter. A 12V power cable and adapters for different valve sizes are included.



BRAVO BST12 HP pneumatic compressor

Two-stage electric pneumatic compressor for boats with 12V power supply, maximum capacity of 450 l/min. and adjustable pressure up to 300 mbar, equipped with a cable length of 3 m with battery connectors. The kit includes a carrying bag and a set of universal adapters.

Package size:
21 x 24 x 18 cm



Foot pump (5 l)

A simple and reliable pump. Made in Russia. Bellows made of rather thick plywood and durable PVC fabric (similar to boat fabric).

Pressure: 400 mbar
Volume: 5 l

Size:
20 x 27 x 7 cm





Waterjet nozzles

Intake (water)

Waterjet nozzle - centrifugal pump, for installation on the motor of the boat. Waterjet nozzles are used to increase the boat's passability in critical shallow water conditions.

The motor, equipped with a water cannon, allows the boat to pass through a depth of up to 5 cm.

It is preferable to install motors with waterjet nozzles on SOLAR boats of Jet Tunnel series.



Quick release

With our quick release, you don't have to dismantle the waterjet nozzle to remove it from the engine!

The quick release consists of two halves, one fixed to the end plane of the deadwood, the other to the waterjet nozzle. After removing the screw gearbox from the motor, all you have to do is to screw in the four bolts, and the nozzle is in the right place!



Intake (water) OFF-ROADER

Made of polyurethane with a Shore durometer' of 95-98, has a high abrasion resistance, durability, well-quenched vibration, and retains its properties at a temperature of -60 to +110 degrees.

Grate plates and manifold washers made of steel 3.2 mm HARDOX 450

Design features:

- There is no gap between the form of the water intake and the plates of the grate, which makes it possible to reduce the impact on the axis of the grate.
- The inlet area is considerably larger than the original.
- Manifold washers are in the form of a crescent right at 3 fixing holes in the water intake and injected into the body of the water intake, to prevent detachment.
- The axles are more drowned into the body of the water intake.

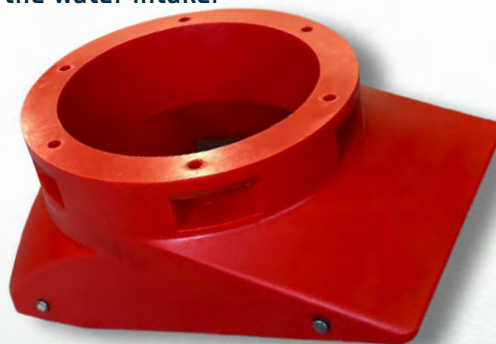

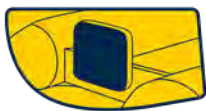

Extras for transom

LPIB transom chassis

The transport wheels allow for ease of moving the boat on land.

A fully assembled boat may be at times difficult to launch and maneuver if water access is limited. The transport wheels will help with launching and recovering the boat without assistance.



Our wheels are designed specifically for low-pressure inflatable boats (LPIB). Made of stainless steel, they have two locking positions:

- upper (for transport);
- lower (working).

The structure is installed on the outer side of the transom, where there is a special fastener.

Adaptive transom plates [with absorber]

Materials:

- monolithic polycarbonate 5 mm;
- PVC fabric;
- gas-oil shock absorbers;
- shock absorber buckles for fixing to transom plates.

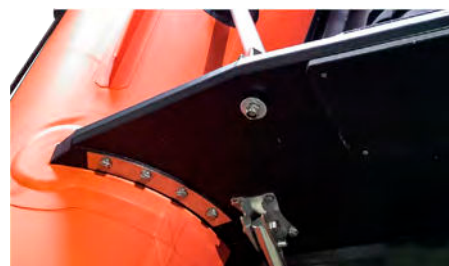

Transom attachment for the installation of an outboard waterjet engine

It has a stainless steel fastener and an overlay for the outboard motor mounting stop.

Dimensions:
400x400 cm

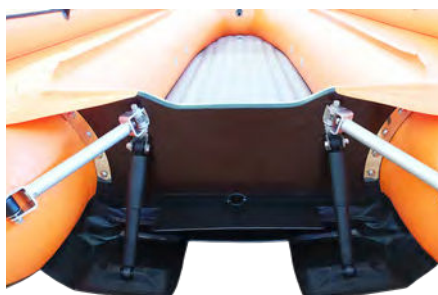

Transom reinforcement

Designed to increase the durability of transom mounting to the tubes to allow for installation of larger HP motors. Provides secure fitment of the U-profile to the transom and prevent early failure of the transom in cases of bottom strikes.





Chairs

Soft folding chair **F4040**

The width of the seat is 41cm and it can accommodate a full grown adult. The seats are padded and work well for winter activities.

Materials:

- Foam with marine vinyl. The vinyl is extremely resistant to UV rays, pleasant to the touch and water proof.



«Pixel»



«Olive»



«Grey-orange»



«Grey-blue»

*«Pixel» with PVC fabric



Fasteners

Oar holder

Used to securely mount the oars to the boat. Also used to mount engine control cables.

Rubber loop

Used to secure rope or carabiners to the boat surface

Tent support

Used to attach the transformer tent to the tubes of the boat

Anchor eye with metal ring

Used on all boats and designed for the attachment or anchor rope and other securement devices.

Tent tip

Used for installing tent frames and consoles of the support tent.





Take these with you outdoors!

IRIS 800 box



Dimensions:
78,5x37x32,5 cm
Load: 120 kg
Volume: 64 l

IRIS 700 box



Dimensions: 70,2x37x39 cm
Load: 80 kg
Volume: 62 l

IRIS 25B box



Dimensions: 41x31x32,5 cm
Load: 180 kg
Volume: 25 l

IRIS 460 box



Dimensions: 45,5x36x35 cm
Load: 120 kg
Volume: 28 l

Cargo distribution scheme for all models of SOLAR boats

The maximum cargo capacity of a boat is the total weight of people + engine weight + fully filled fuel tank + various additional loads.

For maximum stability of the boat on the water it is important to adhere to the norms of correct load distribution in the boat.

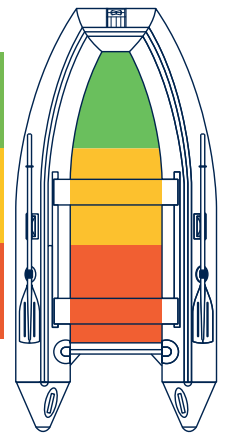
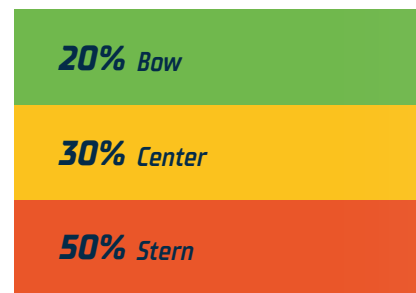

Jet outboard installation scheme for tunnel SOLAR motorboats

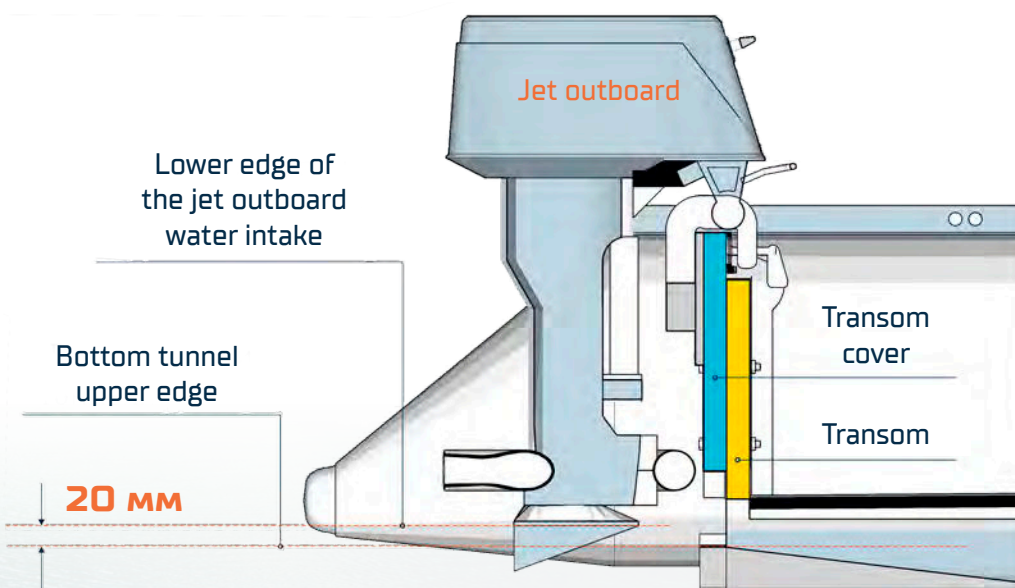

Center the motor on the transom cover.

Tighten the clamping transom screws of the clamping brackets all the way to the limit. Make sure that the motor is positioned exactly in the middle of the transom, otherwise the boat will drag to the side as it moves.

Be sure to attach a safety rope to the motor to prevent it from sinking in the event of a transom failure. Fasten the other end of the safety rope securely to the stern eye rim of the boat.

We make your rivers longer

SOLAR

Solar LLC, Novosibirsk Region,
Novosibirsk city, 21 Tukhachevskogo St.,
Tel./fax: +7 (800) 511-28-40
Sales department +7 (383) 312-04-92
Service +7 (383) 312-04-62
solarboat@solarboat.ru

www.solarboat.ru